

PRODUCT DESCRIPTION

optibelt ZR TIMING BELTS

ISO 5296



Nominal size

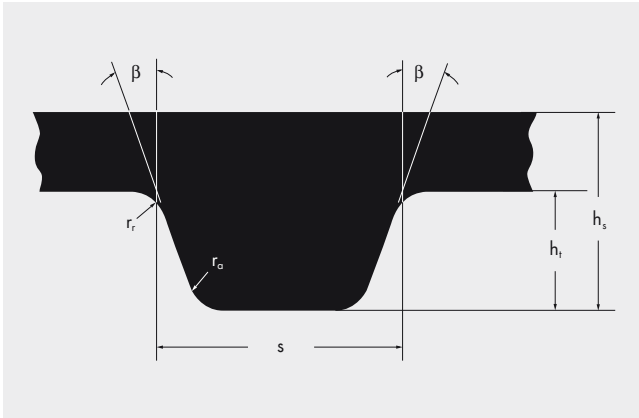

Table 2: Profile dimensions

Profile	MXL	XL	L	H	XH	XXH
Tooth angle 2β [°]	40	50	40	40	40	40
Tooth height h_t [mm]	0.51	1.27	1.91	2.29	6.35	9.53
Foot radius r_f [mm]	0.13	0.38	0.51	1.02	1.57	2.29
Head radius r_a [mm]	0.13	0.38	0.51	1.02	1.19	1.52
Tooth width s [mm]	1.14	2.57	4.65	6.12	12.57	19.05
Overall belt thickness h_s [mm]	1.2	2.3	3.6	4.0	11.2	15.7

Table 3: Width tolerances for optibelt ZR timing belts according to ISO 5296

Profile	Standard width		Allowed deviation of width for belt pitch lengths		
	Dimension [mm]	Width code	Up to 838.20 mm	Over 838.20 mm up to 1676.40 mm	Over 1676.40 mm
			[mm]	[mm]	[mm]
MXL	3.2	012	+ 0.5 - 0.8	-	-
	4.8	019			
	6.4	025			
XL	6.4	025	+ 0.5 - 0.8	+ 0.5 - 0.8	-
	7.9	031			
	9.5	037			
L	12.7	050	+ 0.8 - 0.8	+ 0.8 - 1.3	+ 0.8 - 1.2
	19.1	075			
	25.4	100			
H	19.1	075	+ 0.8 - 0.8	+ 0.8 - 1.3	+ 0.8 - 1.3
	25.4	100			
	38.1	150			
	50.8	200			
XH	76.2	300	+ 1.3 - 1.5	+ 1.5 - 1.5	+ 1.5 - 2.0
	101.6	400			
XXH	50.8	200	+ 4.8 - 4.8	+ 4.8 - 4.8	+ 4.8 - 4.8
	76.2	300			
	101.6	400			
XXH	127.0	500	+ 4.8 - 4.8	+ 4.8 - 4.8	+ 4.8 - 4.8

Weight per metre

Profile	MXL	XL	L	H	XH	XXH
kg/m per 1 mm width	0.0012	0,0021	0.0035	0.0041	0.0110	0.0147