

M129

REVOLVING HANDLE WITH HEXAGONAL SOCKET STUD



Materials:

Reinforced polyamide.
Resistant to oils and greases.

Surface finish:

Satin.

Colour:

Black (RAL 9011).

Inserts:

M129:

Revolving galvanised steel threaded stud, with hexagon socket head and harmonic steel rotating spring (thread tolerance 6g).

M129CIN:

Revolving stainless steel threaded stud (Aisi 303), with hexagon socket head and stainless steel rotating spring (Aisi 302) (thread tolerance 6g).

Special Requests:

- Upon request and for special quantities available in the colours indicated in the chart [page].

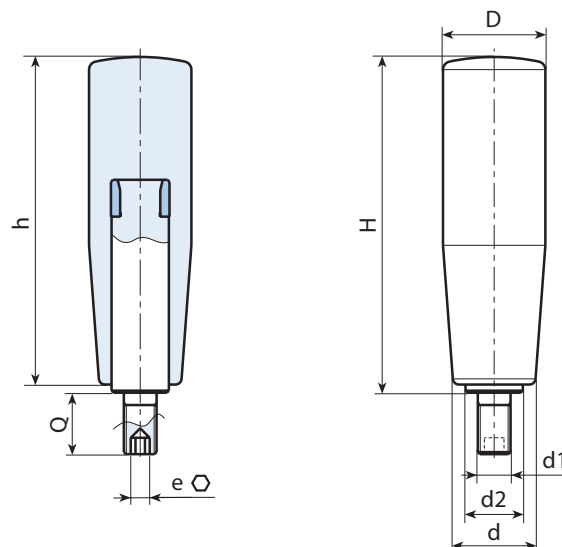

Version M129: with galvanised steel insert.

Code	art.	H	h	D	d	d2	e	d1 _{6g}	Q	
-	M12950.TM06X1201	52	50,5	20	15	10	3	M6	12	42
-	M12960.TM06X1201	62,5	60,5	23,5	18	10	3	M6	12	54
-	M12960.TM08X1501	62,5	60,5	23,5	18	10	4	M8	15	60
-	M12970.TM08X1501	72	70	25	18,5	10	4	M8	15	92
-	M12970.TM10X1501	72	70	25	18,5	10	4	M10	15	94
-	M12980.TM08X1501	81.5	79	26	22	14	4	M8	15	98
-	M12980.TM10X1501	81.5	79	26	22	14	5	M10	15	104
-	M12980.TM12X1501	81.5	79	26	22	14	5	M12	15	104
-	M12990.TM10X1501	92	89,5	28	23,5	14	5	M10	15	118
-	M12990.TM12X1501	92	89,5	28	23,5	14	5	M12	15	120

Version M129CIN: with stainless steel insert (Aisi 303).

INOX

Code	art.	H	h	D	d	d2	e	d1 _{6g}	Q	
-	M12950.TM06X1201CIN	52	50,5	20	15	10	3	M6	12	42
-	M12960.TM06X1201CIN	62,5	60,5	23,5	18	10	3	M6	12	54
-	M12960.TM08X1501CIN	62,5	60,5	23,5	18	10	4	M8	15	60
-	M12970.TM08X1501CIN	72	70	25	18,5	10	4	M8	15	92
-	M12970.TM10X1501CIN	72	70	25	18,5	10	4	M10	15	94
-	M12980.TM08X1501CIN	81.5	79	26	22	14	4	M8	15	98
-	M12980.TM10X1501CIN	81.5	79	26	22	14	5	M10	15	104
-	M12980.TM12X1501CIN	81.5	79	26	22	14	5	M12	15	104
-	M12990.TM10X1501CIN	92	89,5	28	23,5	14	5	M10	15	118
-	M12990.TM12X1501CIN	92	89,5	28	23,5	14	5	M12	15	120