

D207



TWO-SPOKE CONTROL HANDWHEEL WITH REVOLVING FOLDAWAY HANDLE

Materials:

Reinforced and stabilized polyamide. Resistant to oils and greases.

Surface finish:

Satin.

Colour:

Black (RAL 9011).

Central cap:

Grey polyamide (RAL 7035). 13).

Alternative cap colours:

Orange (RAL 2004 code 02).
 Blue (RAL 5015 code 07).
 Yellow (RAL 1021 code 10).
 Red (RAL 3000 code 16).
 Green (RAL 6024 code 17).
 Black (RAL 9011 code 01).

Main insert:

Galvanised steel insert with smooth through bore (tolerance H10).

Lateral handle:

Flush, foldaway revolving handle, with hexagonal connection. Reinforced polyamide handle. Black-oxide treated internal mechanism. Fixed with black-oxide treated hexagon socket button head screw ISO 7838.

Hub:

Solid Hub.

Fixing method:

For fixing systems, or execution of keyways or square holes, please refer to the technical notes attached to the catalogue [page].

Special requests:

- Upon request and for a minimum of 50 pieces inserts can be supplied with hole d1 with tolerance H7 and black oxide treated finish. Add letters ZB to the standard code. Example: D207130.TD1001PZB.
- Upon request and for special quantities inserts can be supplied with custom hole diameter d1.
- Upon request and for special quantities inserts can be supplied in different materials/with different coatings.
- Upon request and for special quantities spoke handwheels, handles and caps are available in the colours indicated in the chart (reduced range) [page].



D

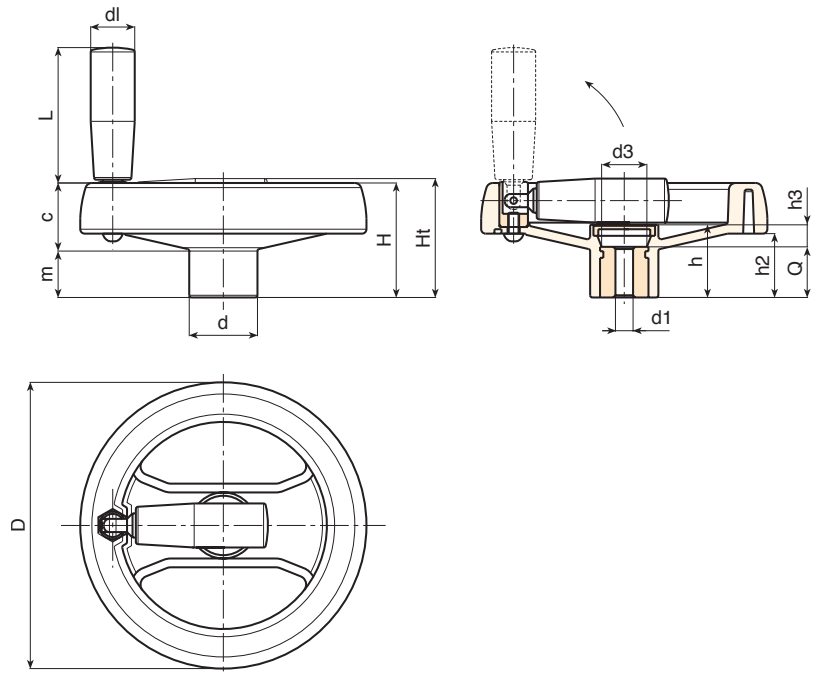

Code	Art.	D	H	Ht	h	d	m	c	h2	h3	d3	dl	L	Dm	d1H10	Q	g
-	D207130.TD0501P	129	53	55	32	32	22	31	30	12	26	20	58	18	5	20	300
-	D207130.TD0801P	129	53	55	32	32	22	31	30	12	26	20	58	18	8	20	297
-	D207130.TD1201P	129	53	55	32	32	22	31	30	12	26	20	58	18	12	20	294
-	D207160.TD0501P	159	55	59	33.5	40	20.5	34.5	31	9.5	26	25	71	22	5	24	450
-	D207160.TD0801P	159	55	59	33.5	40	20.5	34.5	31	9.5	26	25	71	22	8	24	447
-	D207160.TD1201P	159	55	59	33.5	40	20.5	34.5	31	9.5	26	25	71	22	12	24	443
-	D207160.TD1401P	159	55	59	33.5	40	20.5	34.5	31	9.5	26	25	71	22	14	24	440
-	D207160.TD1601P	159	55	59	33.5	40	20.5	34.5	31	9.5	26	25	71	22	16	24	436
-	D207350.TD0801P	346	80	86	49.5	67.5	24	56	43.5	17.5	35	40	64	30	8	32	1650

Attention: For a minimum of 50 pieces the diameter d1 can be customised (hole tolerance H10 galvanised and H7 black-oxide treated). Dm = Maximum obtainable diameter for subsequent machining (widening).